



***Facility Study
For
Generation Interconnection
Request
GEN-2008-029***

SPP Tariff Studies

(#GEN-2008-029)

June 2010

Summary

Oklahoma Gas and Electric performed the following Study at the request of the Southwest Power Pool (SPP) for Generation Interconnection request Gen-2008-029. The request for interconnection was placed with SPP in accordance SPP's Open Access Transmission Tariff, which covers new generation interconnections on SPP's transmission system.

Pursuant to the tariff, Oklahoma Gas and Electric was asked to perform a detailed Facility Study of the generation interconnection request to satisfy the Facility Study Agreement executed by the requesting customer and SPP.

Interconnection Customer Interconnection Facilities

The Interconnection Customer will be responsible for the 138kV transmission line from the point of interconnection to its 138/34.5kV substation that will contain its 138/34.5kV transformer(s) and wind turbine collector feeders. In addition, the Customer will be required to maintain a +/- 95% power factor at the point of interconnection (OG&E Woodward 138kV substation).

Transmission Owner Interconnection Facilities and Non Shared Network Upgrades

The interconnection customer was studied within the DISIS-2009-001 Impact Study. The Interconnection Customer is responsible for \$410,000 of Transmission Owner Interconnection Facilities and \$4,200,000 of non shared Network Upgrades. At this time, the Interconnection Customer is allocated \$0 of shared network upgrades. If higher queued interconnection customers withdraw from the queue, suspend or terminate their LGIA, restudies will have to be conducted to determine the Interconnection Customers' allocation of shared network upgrades.



FACILITY STUDY

for

Generation Interconnection Request 2008-029

251 MW Wind Generating Facility
In Woodward County
Near
Woodward, Oklahoma

May 10, 2010

Steve M. Hardebeck, PE
Lead Engineer
Transmission Planning
OG&E Electric Services

Summary

Pursuant to the tariff and at the request of the Southwest Power Pool (SPP), Oklahoma Gas and Electric (OG&E) performed the following Facility Study to satisfy the Facility Study Agreement executed by the requesting customer for SPP Generation Interconnection request Gen-2008-029. The request for interconnection was placed with SPP in accordance SPP's Open Access Transmission Tariff, which covers new generation interconnections on SPP's transmission system. The requirements for interconnection consist of adding five new 138kV breakers and a terminal in the existing Woodward District EHV Substation. With the addition of a new element the existing six breaker ring will have to be converted to a breaker and a half configuration. This will require the addition of five new breakers. The total cost for OKGE to add five new 138kV breakers and a terminal in the Woodward District EHV substation, the interconnection facility, is estimated at \$4,610,000.

Table of Contents

Table of Contents	3
Introduction	4
Interconnection Facilities	5
Interconnection Costs	6
Overview of Woodward District EHV Substation	7
One-Line diagram of Interconnection	8

Introduction

The Southwest Power Pool has requested a Facility Study for the purpose of interconnecting 251MW of wind generation within the service territory of OG&E Electric Services (OKGE) in Woodward County Oklahoma. The proposed 138kV point of interconnection is at the existing Woodward District EHV Substation in Woodward County. This substation is owned by OKGE. The proposed in-service date is June 01, 2012.

Power flow analysis has indicated that for the power flow cases studied, it is possible to interconnect the 251MW of generation with transmission system reinforcements within the local transmission system. Given the Point of Interconnection at an existing substation, there are additional requirements for interconnection including bus, breaker, switches, relaying, metering, etc.

The cost for adding a new 138kV terminal to the existing Woodward District EHV Substation, the required interconnection facility, is estimated at \$410,000. Other Network Constraints in the American Electric Power West (AEPW), OKGE and Western Farmers Electric Cooperative (WFEC) systems may be verified with a transmission service request and associated studies.

Interconnection Facilities

The primary objective of this study is to identify attachment facilities. The requirements for interconnection consist of adding a new 138kV terminal in the existing Woodward District EHV Substation. This 138kV addition shall be constructed and maintained by OKGE. The Customer did not propose a route of its 138kV line to serve its 138-34.5kV facilities.

The total cost for OKGE to add a new 138kV terminal in the Woodward District EHV substation, the interconnection facility, is estimated at \$410,000. This cost does not include building 138kV line from the Customer substation into the existing Woodward District EHV Substation. The Customer is responsible for this 138kV line up to the point of interconnection. This cost does not include the Customer's 138-34.5kV substation and the cost estimate should be determined by the Customer.

This Facility Study does not guarantee the availability of transmission service necessary to deliver the additional generation to any specific point inside or outside the Southwest Power Pool (SPP) transmission system. The transmission network facilities may not be adequate to deliver the additional generation output to the transmission system. If the customer requests firm transmission service under the SPP Open Access Transmission Tariff at a future date, Network Upgrades or other new construction may be required to provide the service requested under the SPP OATT.

The costs of interconnecting the facility to the OKGE transmission system are listed in Table 1.

Short Circuit Fault Duty Evaluation

It is standard practice for OG&E to recommend replacing a circuit breaker when the current through the breaker for a fault exceeds 100% of its interrupting rating with recloser de-rating applied, as determined by the ANSI/IEEE C37.5-1979, C37.010-1979 & C37.04-1979 breaker rating methods.

For this generator interconnection, no breakers were found to exceed their interrupting capability after the addition of the Customer’s 251MW generation and related facilities. OG&E found no breakers that exceeded their interrupting capabilities on their system. Therefore, there is no short circuit upgrade costs associated with the Gen-2008-029 interconnection.

Table 1: Required Interconnection Network Upgrade Facilities

Facility	ESTIMATED COST (2010 DOLLARS)
OKGE – Interconnection Facilities - Add a single 138kV line terminal to existing Woodward District EHV Substation. Dead end structure, line relaying, revenue metering including CTs and PTs	\$410,000
OKGE – Network Upgrades at Woodward District EHV sub, 5-138kV breakers, line relaying, disconnect switches, and associated equipment	\$4,200,000
OKGE - Right-of-Way for 138kV terminal addition	No Additional ROW
Total	\$4,610,000

Prepared by Steve M. Hardebeck, PE
Lead Engineer, Transmission Planning
OG&E Electric Services

May 10, 2010

Reviewed by:

Philip L. Crissup

Philip L. Crissup
Director, Regional Transmission Affairs

Woodward District EHV Substation Configuration

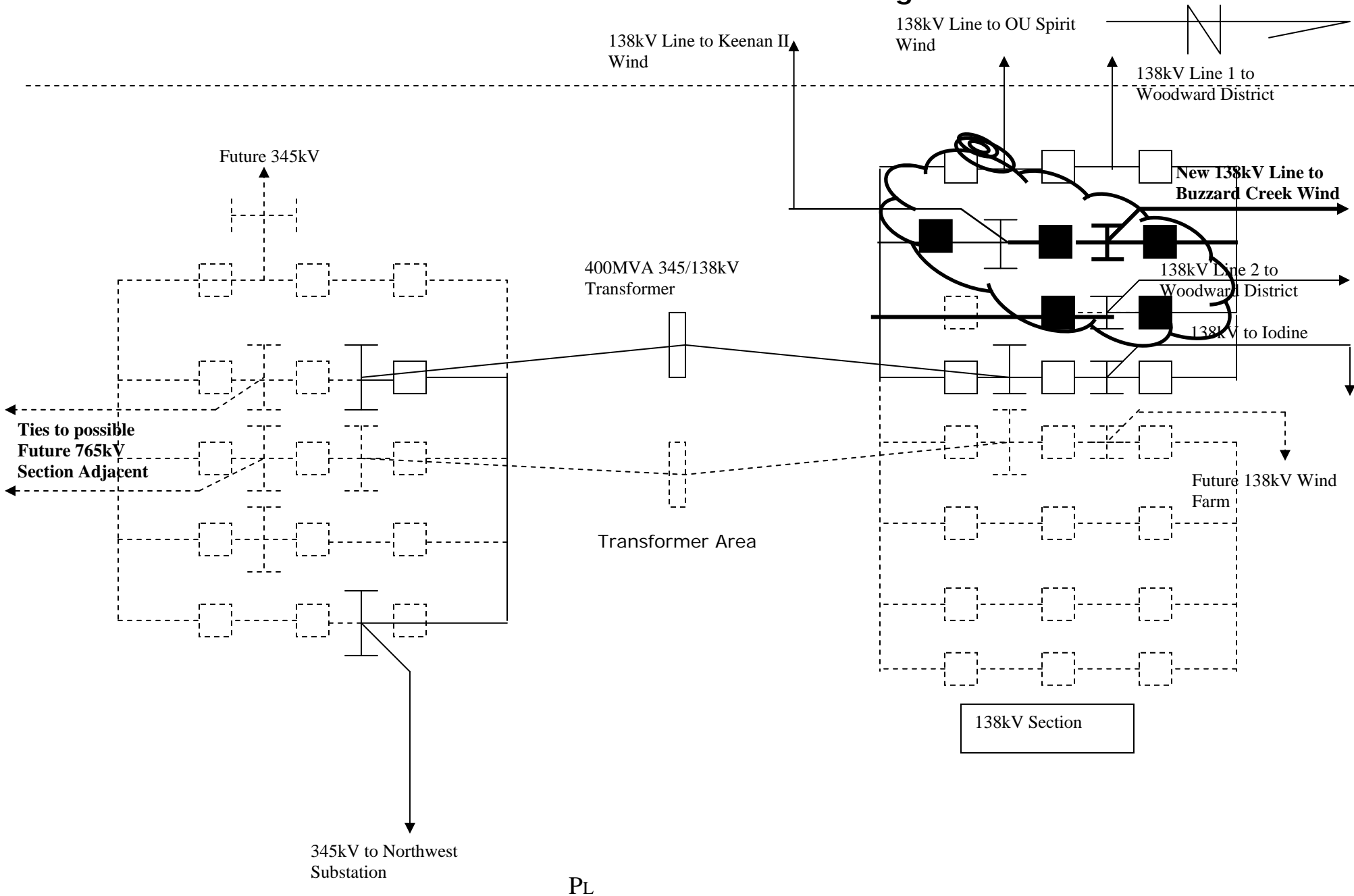

PL